

## **Air-Cooled Mini Chiller and Heat Pump**

**M4AC 080 ÷ 150 C**

**Cooling capacity from 22,4 to 40,0 kW**

**M4AC 080 ÷ 150 CR**

**Cooling capacity from 21,7 to 38,7 kW**

**Heating capacity from 25,6 to 41,5 kW**

**50 Hz – HFC 407 C refrigerant**



**CE**





## Caution

Installation and maintenance are to be performed only by qualified personnel who are familiar with local codes and regulations, and experienced with this type of equipment.  
McQuay is not responsible for any unit damage, personal injury or death due to not complying with these requirements.



## Warning

Sharp edges and coil surfaces are a potential injury hazard. Avoid contact with them.



## Warning

Moving machinery and electrical power hazards may cause severe personal injury or death. Disconnect and lock off power before servicing equipment.

"McQuay" is a registered trademark of McQuay International. All rights reserved throughout the world.  
2002 McQuay International

"Bulletin illustrations cover the general appearance of McQuay International products at the time of publication and we reserve the right to make changes in design and construction at any time without notice."

## Introduction

For years, McQuay international has earned a reputation for providing the industry with various highest quality and most technologically advanced air conditioning systems. Now McQuay is proud to introduce the new generation mini air-cooled chiller-M4AC C series. Inherited from the advantage of the earlier product experiences and introduced the most up-to-date technology, the new M4AC C series are designed with the always-in-mind concept - to satisfy customers' requirements of high efficiency, comfort, safety, intelligence to maximum extent. The unit can be flexibly coupled with multi fan coil units, easily operated with artificial intelligence. Additionally combined with indoor top level decoration, this bring you to enjoy the nobility coming from central air conditioning.

Providing the features such as high efficiency, low noise, compactness, simple operation, safety running, easy installation and maintenance etc., the unit is widely equipped in plant, station, hotel, villa, office building, top-level apartment as well as process cooling application.

## Nomenclature

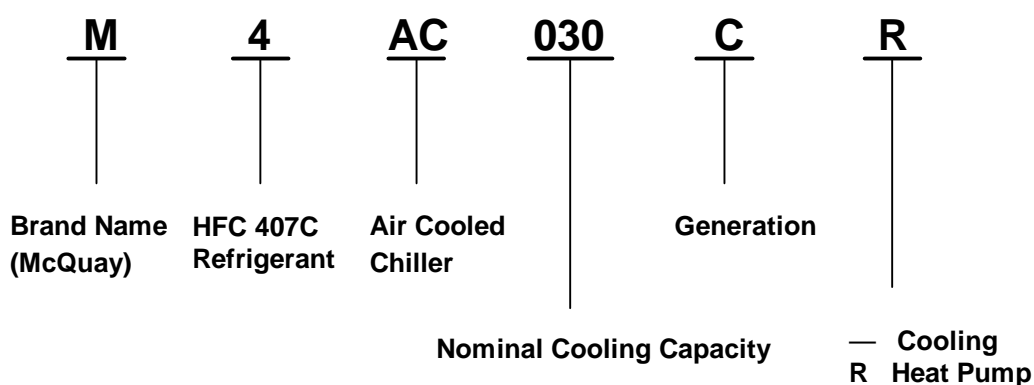

## Features

### Superior Performance

Extensive research work coupled with world leading manufacturing technology has resulted the new design with superb performance and high efficiency.

Stringent quality control and component selection ensure performance and reliability. Major components are rigorously tested and qualified prior to usage in the machine.

Every machine design has passed many hours of rigorous testing to ensure the machine reliability, durability and quality. Scroll compressor brings much higher energy efficiency. High efficiency heat exchanger ensures strenuous exertion of equipment capacity. Dedicated water pump particularly designed for air conditioning engineering is operating steadily with minimum vibration and noise.

**M4AC080C/CR To M4AC150C/CR** units are designed with double independent refrigerating system, greater energy saving is achieved by only one compressor on duty under part load condition.

### Simple To Operate

The machine is complete with intelligent microprocessor controller and temperature sensor to automatically control the operation to its optimum condition, making it very simple to operate. All temperature settings are finished before shipment. The only thing for user to do is to start the unit by pressing the ON/OFF button after ensuring unit proper function, then every operation can be automatically performed by the unit itself.

Either wireless remote controller or wired remote controller is ready for choosing to meet satisfactory indoor unit control, both compatible with the unit.

### Friendly Installation

The machine has been designed with friendly installation in mind such that no refrigeration charging or copper pipe brazing is required on site.

Threaded fitting is provided for easy water piping connection on site.

Water inlet and outlet are provided on both sides of the machine such that piping can be connected on either side of the machine.

Rust resistant PP-R composite water pipe with good insulation property and high durability is standard parts in the machine.

Stainless steel taper threaded fittings target convenient disassembly or assembly.

For M4AC080C/CR to M4AC150C/CR, expansion chamber, water pump and water flow switch are already equipped in this compact packaged unit with top air discharge. Both front and rear sides can be served as access to performing wiring and maintenance.

### Safety Control

Protection devices such as dual pressure protection and overload protection etc. is provided to ensure unit operating within safety condition range. The microprocessor-based controller automatically directs system on or off by processing the water temperature feedback. If the water temperature falls to unacceptable low point, the controller automatically shut off the system to prevent hydraulic system internal freeze for unit safety operation. Meanwhile, the microprocessor-based controller automatically monitors every component operating status and malfunction, and feedback it to indoor controller to greatly ease the work of status monitor and troubleshooting.

### All Weather

The cabinet is made of electro galvanized mild steel sheet, coated with baked polyester powder to ensure the units extra durability in all climates against sun, rain, wind corrosion.

Space saving (small footprint) design of the machine eliminates large installation area requirement, no need for equipment room.

The machine uses high quality parts to ensure durability in various climate conditions.

### Simple To Maintain

The simple design of the machine allows for maximum serviceability. All components are within reach of the maintenance personnel upon opening of the servicing panel. If emergency shutoff occurs, the microprocessor-based controller will indicate the fault cause to quicken and ease troubleshooting.

## **General Specification**

### **Compressor**

McQuay Mini Chillers M4AC080C(R) to M4AC150C(R) are equipped with highly efficient, reliable and silence scroll compressors.

### **Air-Cooler Condenser**

The air-cooled condenser coil consists of staggered rows of 3/8" O.D. seamless copper tube, mechanically expanded into die formed aluminum fins to ensure optimum heat exchange capability.

### **Condenser Fan Motor**

To achieve the high air change requirement, the unit is equip with the high air flow propeller fan. The fan is direct driven by weatherproof motor to ensure reliable continuous operation.

### **Evaporator**

The heat exchanger is made of stainless steel plates closely arranged and brazed together to ensure high heat exchange efficiency. The complete heat exchanger is insulated with thermal insulation closed cell rubber foam to give optimum thermal insulation.

### **Refrigerant Circuit**

The refrigerant circuit is factory brazed and evacuated before accurately charged with HFC 407C to ensure optimum operating requirement. To ensure flawless continuous operation, each refrigerant circuit is equipped with a carefully sized capillary tube.

### **Additional Safety Protection**

The units are equipped with intelligently designed safety control to ensure continuous safe operation. High and low pressure switch is provided to prevent the compressor damage resulting from both abnormally high discharge head pressure or low pressure due to insufficient gas. The compressors are provided with crank case heater to prevent liquid migration during the off cycle and also to ease the start up of the unit.

The standard electronic controller provides accurate water temperature control in the circuit by closely monitoring and reacting to the input from the water entering temperature, water leaving temperature and ambient air temperature.

Flow switch is provided in the unit to protect against damage to the water pump.

During abnormal condition, the electronic controller will turn the unit off and the then display the faulty of operation. (See **Troubleshooting** sheet)

# Controller

The controller accomplishes its control function with its built-in microprocessor. The two parameters, temperature and water flow rate, have been factory set before shipment, no need for users to reset them. The controller will display unit operation status to favor specialized personnel to monitor unit operating condition for maintenance if necessary. When the system is cut off due to malfunction, the controller will display the corresponding failure code for easy trouble shooting.

## Installation and connection

After removing the terminal box cover, you will find the indoor controller, 20m long indoor connection wire, and 1.5m long maintenance connection wire. Decide a suitable place for installing the indoor controller, you can either mount it on wall or embed it in wall. Open the back cover of the indoor controller, plug one end of the indoor connection wire to the CN3 connector located on controller, insert another end to the CN6 connector located on PCB, then assembly the terminal box cover back, now this work is finished.

Please ensure the 1.5m maintenance connection wire being in good keep for later maintenance by specialized personnel.

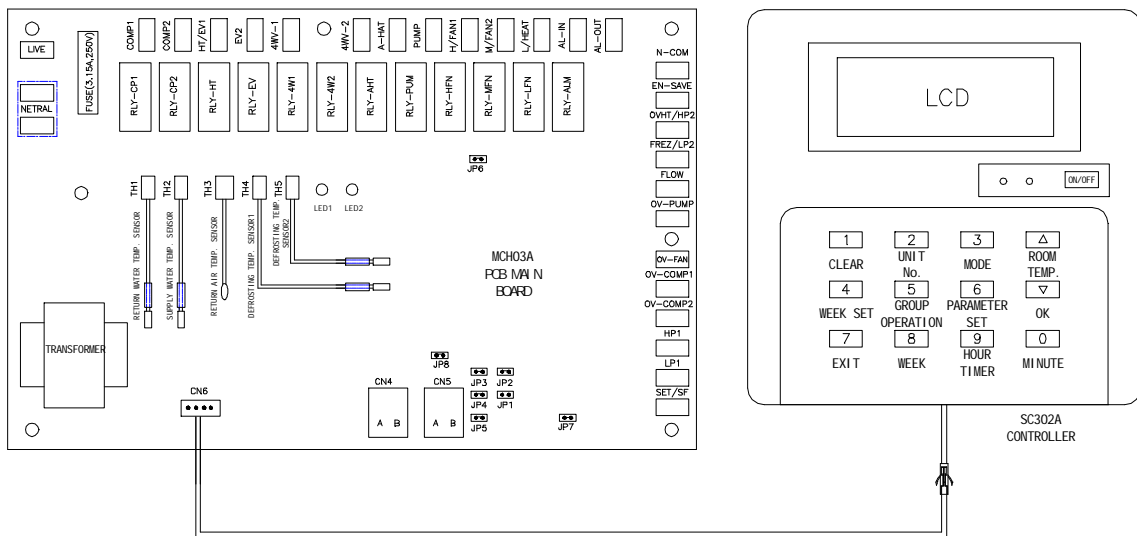

## Indoor LCD controller

After switching on power, the indoor controller will display system time, indoor temperature and unit status. During normal operation, it will display the unit return water temperature. When failure occurs, it will emit alarm, both audible and visual. Meanwhile show a corresponding error code. Please see **Troubleshooting With Microprocessor** sheet.

### a) On/off

Start an operation  
 First press [MODE] button, select “cooling” or “heating” mode, then press [ON/OFF] button, the yellow lamp besides the [ON/OFF] button lights up and the system starts.  
 Stop an operation  
 Press the [ON/OFF] button again, the yellow lamp goes off and the system stops.

### b) Indicating lamps on PCB

When the power supply is switched on, the red lamp lights up.  
 When the system is on operation, the green lamp lights up.

### c) Below are the controllers’ protection functions and features, not its faults.

When restarting the unit after last start or stop, the unit automatically starts compressor and fan after the lapse of approximately three minutes.  
 During defrosting cycle, the outdoor fan is stopped.

## Cooling Only Unit

MODEL		M4AC080C	M4AC100C	
NOMINAL COOLING CAPACITY		kcal/hr	19.260	22.960
		Watt	22.400	26.700
CASING	MATERIAL	Electro-galvanised Mild Steel		
	FINISH	Polyester Power		
	THICKNESS	mm	1,0	
TOTAL UNIT DIMENSION	HEIGHT (H)	mm (in)	1260 (49.6)	
	WIDTH (W)	mm (in)	1500 (59.1)	
	DEPTH (D)	mm (in)	900 (35.4)	
NET WEIGHT		kg	340	350
NOISE LEVEL		dB(A)	62	64
<b>EVAPORATOR</b>				
TYPE		Braze Plate Heat Exchanger		
PLATE MATERIAL		Stainless Steel		
HEAT EXCHANGE AREA		m <sup>2</sup>	2,26	2,78
NOMINAL WATER FLOW		l/s	1,08	1,31
BPHE PRESSURE DROP VS NOMINAL FLOW RATE		kPa	74	82
UNIT PRESSURE DROP WS NOMINAL FLOW RATE		kPa	104	121
<b>WATER LINE(HYDRAULIC KIT)</b>				
PUMP	TYPE	Horizontal Multistage End-Suction		
	POWER SUPPLY	V/Ph/Hz	380 / 3 / 50	
	RUNNING CURRENT	Amp	1,1	1,1
	WATER FLOW RATE	GPM U.S. (l/s)	17.17(1.08)	20.70(1.31)
PIPING	INSTALLATION PIPE CONNECTION	mm (in)	42 (Rc 1-1/4)	42 (Rc 1-1/4)
	HEAD	m	26	23,5
EXPANSION TANK	MATERIAL	Steel		
	CAPACITY / VOLUME	litres	8	8
<b>CONDENSER COIL</b>				
TYPE		Cross Finned Tubes		
TUBE	MATERIAL	Seamless Copper		
	WALL THICKNESS	mm (in)	0.35 (0.014)	
	OUTER DIAMETER	mm (in)	9.52 (3/8)	
FIN	MATERIAL	Aluminium		
	THICKNESS	mm (in)	0.127 (0.0005)	
	ROWS		2	2
	FINS PER INCH		14	14
FACE AREA		m <sup>2</sup> (ft <sup>2</sup> )	2.5 (26.9)	2.5 (26.9)
<b>CONDENSER FAN</b>				
TYPE/DRIVE		Propeller/Direct		
QUANTITY		2	2	
BLADE MATERIAL		Aluminium		
BLADE DIAMETER		mm (in)	600 (23.6)	600 (23.6)
POWER SUPPLY		V/Ph/Hz	220 / 1 / 50	220 / 1 / 50
RATED RUNNING CURRENT		Amp	0.9*2	0.9*2
RATED INPUT		Watt	120*2	120*2
RATED OUTPUT		Watt	200*2	200*2
MOTOR POLES			8	8
AIR VOLUME		cmm/cfm	100*2 / 3530*2	100*2 / 3530*2
<b>COMPRESSOR</b>				
TYPE		Scroll		
POWER SUPPLY		V/Ph/Hz	380 / 3 / 50	380 / 3 / 50
RATED RUNNING CURRENT		Amp	7.3*2	8.6*2
RATED INPUT		Watt	3,900*2	4,800*2
MAXIMUM STARTING CURRENT		Amp	40	48
PROTECTION DEVICES		Overload Protection, Flow Switch & H/L Pressure Switch		
STAGE OF CAPACITY CONTROL (%)		0-50-100		
<b>REFRIGERANT</b>				
TYPE		HFC407C		
CONTROL		Capillary Tube		
CHARGING MASS		kg	3.5*2	3.3*2

**Note:**

(1) Nominal cooling capacity referred to 12/7 ° C in/out evaporator water temperature 35 ° C air ambient temperature

## Cooling Only Unit

MODEL		M4AC120C	M4AC150C
NOMINAL COOLING CAPACITY		kcal/hr	28.720
		Watt	33.400
CASING	MATERIAL	Electro-galvanised Mild Steel	
	FINISH	Polyester Power	
	THICKNESS	mm	1
TOTAL UNIT DIMENSION	HEIGHT (H)	mm (in)	1260 (49.6)
	WIDTH (W)	mm (in)	1800 (70.9)
	DEPTH (D)	mm (in)	1150 (45.3)
NET WEIGHT		kg	470
NOISE LEVEL		dB(A)	67
550			70
<b>EVAPORATOR</b>			
TYPE		Braze Plate Heat Exchanger	
PLATE MATERIAL		Stainless Steel	
HEAT EXCHANGE AREA		m <sup>2</sup>	3,0
NOMINAL WATER FLOW		l/s	1,67
BPHE PRESSURE DROP VS NOMINAL FLOW RATE		kPa	76
UNIT PRESSURE DROP VS NOMINAL FLOW RATE		kPa	138
<b>WATER LINE(HYDRAULIC KIT)</b>			
PUMP	TYPE	Horizontal Multistage End-Suction	
	POWER SUPPLY	V/Ph/Hz	380 / 3 / 50
	RUNNING CURRENT	Amp	2,5
	WATER FLOW RATE	GPM U.S. (l/s)	26.42(1.67)
PIPING	INSTALLATION PIPE CONNECTION	mm (in)	42 (Rc 1-1/4)
	HEAD	m	31
EXPANSION TANK	MATERIAL	Steel	
	CAPACITY / VOLUME	litres	8
<b>CONDENSER COIL</b>			
TYPE		Cross Finned Tubes	
TUBE	MATERIAL	Seamless Copper	
	WALL THICKNESS	mm (in)	0.35 (0.014)
	OUTER DIAMETER	mm (in)	9.52 (3/8)
FIN	MATERIAL	Aluminium	
	THICKNESS	mm (in)	0.127 (0.0005)
	ROWS		2
	FINS PER INCH		14
FACE AREA	m <sup>2</sup> (ft <sup>2</sup> )	2.5 (26.9)	2.5 (26.9)
<b>CONDENSER FAN</b>			
TYPE/DRIVE		Propeller/Direct	
QUANTITY		2	2
BLADE MATERIAL			
BLADE DIAMETER		mm (in)	660 (26)
POWER SUPPLY		V/Ph/Hz	380 / 3 / 50
RATED RUNNING CURRENT		Amp	0.86*2
RATED INPUT		Watt	200*2
RATED OUTPUT		Watt	470*2
MOTOR POLES			8
AIR VOLUME		cmm/cfm	142*2 / 5000*2
<b>COMPRESSOR</b>			
TYPE		Scroll	
POWER SUPPLY		V/Ph/Hz	380 / 3 / 50
RATED RUNNING CURRENT		Amp	10.3*2
RATED INPUT		Watt	5,300*2
MAXIMUM STARTING CURRENT		Amp	55
PROTECTION DEVICES		Overload Protection, Flow Switch & H/L Pressure Switch	
STAGE OF CAPACITY CONTROL (%)		0-50-100	
<b>REFRIGERANT</b>			
TYPE		HFC 407C	
CONTROL		Capillary Tube	
CHARGING MASS		kg	6.3*2
			5.7*2

**Note:**

(1) Nominal cooling capacity referred to 12/7 ° C in/out evaporator water temperature 35 ° C air ambient temperature



## Heat Pump Unit

MODEL			M4AC080CR	M4AC100CR
NOMINAL COOLING CAPACITY	kcal/hr		18660	22180
	Watt		21.700	25.800
NOMINAL HEATING CAPACITY	kcal/hr		22.010	25.970
	Watt		25.600	30.200
CASING	MATERIAL		Electro-galvanised Mild Steel	
	FINISH		Polyester Power	
	THICKNESS	mm	1,0	
TOTAL UNIT DIMENSION	HEIGHT (H)	mm (in)	1260 (49.6)	
	WIDTH (W)	mm (in)	1500 (59.1)	
	DEPTH (D)	mm (in)	900 (35.4)	
NET WEIGHT		kg	350	360
NOISE LEVEL		dB(A)	62	64
<b>EVAPORATOR</b>				
TYPE			Braze Plate Heat Exchanger	
PLATE MATERIAL			Stainless Steel	
HEAT EXCHANGE AREA		m <sup>2</sup>	2,26	2,78
NOMINAL WATER FLOW (COOLING/HEATING)		l/s	1.08/1.14	1.31/1.39
BPHE PRESSURE DROP VS NOMINAL FLOW RATE (C/H)		kPa	74/72	82/80
UNIT PRESSURE DROP VS NOMINAL FLOW RATE		kPa	104	121
<b>WATER LINE(HYDRAULIC KIT)</b>				
PUMP	TYPE		Horizontal Multistage End-Suction	
	POWER SUPPLY	V/Ph/Hz	380 / 3 / 50	
	RUNNING CURRENT	Amp	1,1	1,1
WATER FLOW RATE ( C / H )		GPM U.S. (l/s)	17.17(1.08)/18.05(1.14)	20.70(1.31)/22.02(1.39)
PIPING	INSTALLATION PIPE CONNECTION		42 (Rc 1-1/4)	
	HEAD (C / H)		26/25	
EXPANSION TANK	MATERIAL		Steel	
	CAPACITY / VOLUME		litres	
			8	8
<b>CONDENSER COIL</b>				
TYPE			Cross Finned Tubes	
TUBE	MATERIAL		Seamless Copper	
	WALL THICKNESS	mm (in)	0.35 (0.014)	
	OUTER DIAMETER	mm (in)	9.52 (3/8)	
FIN	MATERIAL		Aluminium	
	THICKNESS	mm (in)	0.127 (0.0005)	
	ROWS		2	2
	FINS PER INCH		14	14
FACE AREA		m <sup>2</sup> (ft <sup>2</sup> )	2.5 (26.9)	2.5 (26.9)
<b>CONDENSER FAN</b>				
TYPE/DRIVE			Propeller/Direct	
QUANTITY			2	2
BLADE MATERIAL			Aluminium	
BLADE DIAMETER		mm (in)	600 (23.6)	600 (23.6)
POWER SUPPLY		V/Ph/Hz	220 / 1 / 50	220 / 1 / 50
RATED RUNNING CURRENT		Amp	0.9*2	0.9*2
RATED INPUT		Watt	120*2	120*2
RATED OUTPUT		Watt	200*2	200*2
MOTOR POLES			8	8
AIR VOLUME		cmm/cfm	100*2 / 3530*2	100*2 / 3530*2
<b>COMPRESSOR</b>				
TYPE			Scroll	Scroll
POWER SUPPLY		V/Ph/Hz	380 / 3 / 50	380 / 3 / 50
RATED RUNNING CURRENT (COOLING)		Amp	7.3*2	8.6*2
RATED RUNNING CURRENT (HEATING)		Amp	7.3*2	8.6*2
RATED INPUT (COOLING)		Watt	3,900*2	4,800*2
RATED INPUT (HEATING)		Watt	3,900*2	4,800*2
MAXIMUM STARTING CURRENT		Amp	40	48
PROTECTION DEVICES			Overload Protection, Flow Switch & H/L Pressure Switch	
STAGE OF CAPACITY CONTROL (%)			0-50-100	
<b>REFRIGERANT</b>				
TYPE			HFC 407C	
CONTROL			Capillary Tube	
CHARGING MASS		kg	4.0*2	4.6*2

**Note:**

- (1) Nominal cooling capacity referred to 12/7 ° C in/out evaporator water temperature 35 ° C air ambient temperature  
 (2) Heating capacity referred to: 40/45°C in/out Hot water temp. & air ambient temperature. 7°C, 90% R.H.

## Heat Pump Unit

MODEL			M4AC120CR	M4AC150CR
NOMINAL COOLING CAPACITY	kcal/hr		27.690	33.280
	Watt		32.200	38.700
NOMINAL HEATING CAPACITY	kcal/hr		31.210	35.680
	Watt		36.300	41.500
CASING	MATERIAL		Electro-galvanised Mild Steel	
	FINISH		Polyester Power	
	THICKNESS	mm	1	
TOTAL UNIT DIMENSION	HEIGHT (H)	mm (in)	1260 (49.6)	
	WIDTH (W)	mm (in)	1800 (70.9)	
	DEPTH (D)	mm (in)	1150 (45.3)	
NET WEIGHT	kg		480	560
NOISE LEVEL	dB(A)		67	70
<b>EVAPORATOR</b>				
TYPE			Brazeed Plate Heat Exchanger	
PLATE MATERIAL			Stainless Steel	
HEAT EXCHANGE AREA		m <sup>2</sup>	3,0	3,6
NOMINAL WATER FLOW (COOLING/HEATING)		l/s	1.67/1.78	2.0/2.11
BPHE PRESSURE DROP VS NOMINAL FLOW RATE (CH)		kPa	76/74	75/73
UNIT PRESSURE DROP VS NOMINAL FLOW RATE		kPa	138	155
<b>WATER LINE(HYDRAULIC KIT)</b>				
PUMP	TYPE		Horizontal Multistage End-Suction	
	POWER SUPPLY	V/Ph/Hz	380 / 3 / 50	
	RUNNING CURRENT	Amp	2,5	2,5
PIPING	WATER FLOW RATE (C / H)	GPM U.S. (l/s)	26.42(1.67)/28.18(1.78)	31.70(2.0)/33.47(2.11)
	INSTALLATION PIPE CONNECTION	mm (in)	42 (Rc 1-1/4)	42 (Rc 1-1/4)
EXPANSION TANK	HEAD (C / H)	m	31/29	28/26
	MATERIAL		Steel	
CAPACITY / VOLUME		litres	8	8
<b>CONDENSER COIL</b>				
TYPE			Cross Finned Tubes	
TUBE	MATERIAL		Seamless Copper	
	WALL THICKNESS	mm (in)	0.35 (0.014)	
	OUTER DIAMETER	mm (in)	9.52 (3/8)	
FIN	MATERIAL		Aluminium	
	THICKNESS	mm (in)	0.127 (0.0005)	
	ROWS		2	2
	FINS PER INCH		14	14
FACE AREA	m <sup>2</sup> (ft <sup>2</sup> )		2.5 (26.9)	2.5 (26.9)
<b>CONDENSER FAN</b>				
TYPE/DRIVE			Propeller/Direct	
QUANTITY			2	2
BLADE MATERIAL				
BLADE DIAMETER	mm (in)		660 (26)	660 (26)
POWER SUPPLY		V/Ph/Hz	380 / 3 / 50	
RATED RUNNING CURRENT		Amp	0.86*2	4.5*2
RATED INPUT		Watt	200*2	450*2
RATED OUTPUT		Watt	470*2	820*2
MOTOR POLES			8	6
AIR VOLUME	cmm/cfm		142*2 / 5000*2	142*2 / 5000*2
<b>COMPRESSOR</b>				
TYPE			Scroll	Scroll
POWER SUPPLY		V/Ph/Hz	380 / 3 / 50	380 / 3 / 50
RATED RUNNING CURRENT (COOLING)		Amp	10.3*2	11.5*2
RATED RUNNING CURRENT (HEATING)		Amp	10.3*2	11.5*2
RATED INPUT (COOLING)		Watt	5,300*2	6,240*2
RATED INPUT (HEATING)		Watt	5,300*2	6,240*2
MAXIMUM STARTING CURRENT		Amp	55	62
PROTECTION DEVICES			Overload Protection, Flow Switch & H/L Pressure Switch	
STAGE OF CAPACITY CONTROL (%)			0-50-100	
<b>REFRIGERANT</b>				
TYPE			HFC 407C	
CONTROL			Capillary Tube	
CHARGING MASS	kg		7.5*2	6.8*2

**Note:**

- (1) Nominal cooling capacity referred to 12/7 ° C in/out evaporator water temperature 35 ° C air ambient temperature  
 (2) Heating capacity referred to: 40/45°C in/out Hot water temp. & air ambient temperature. 7°C, 90% R.H.

## Cooling Only

Unit Size	Leaving water temperature °C	Ambient Temperature °C									
		28		32		35		40		42	
		Cooling Cap.ty kW	Power input kW	Cooling Cap.ty kW	Power input kW	Cooling Cap.ty kW	Power input kW	Cooling Cap.ty kW	Power input kW	Cooling Cap.ty kW	Power input kW
M4AC080C	5*	23,4	6,6	22,1	7,3	21,2	7,7	20,1	8,1	18,7	8,7
	6*	24,2	7,2	22,9	7,8	22,0	8,2	20,8	8,6	19,5	9,2
	7	24,6	7,5	23,3	8,3	22,4	8,6	21,3	9,1	19,9	9,7
	8	25,0	8,0	23,7	8,7	22,9	9,1	21,7	9,5	20,2	10,0
	9	25,6	8,6	24,2	9,4	23,4	9,7	22,2	10,1	20,8	10,7
	10	26,3	9,3	25,0	10,1	24,2	10,8	22,9	10,8	21,5	11,4
M4AC100C	5*	27,8	7,5	26,3	8,2	25,2	8,6	23,9	9,1	22,3	9,7
	6*	28,8	8,1	27,2	8,8	26,1	9,2	24,8	9,6	23,2	10,3
	7	29,2	8,5	27,7	9,3	26,7	9,6	25,3	10,1	23,6	10,8
	8	29,8	9,0	28,2	9,7	27,2	10,1	25,8	10,6	24,0	11,2
	9	30,4	9,7	28,8	10,5	27,8	10,8	26,4	11,3	24,8	12,0
	10	31,2	10,5	29,7	11,3	28,8	12,1	27,2	12,1	25,6	12,7
M4AC120C	5*	34,8	8,4	32,9	9,2	31,5	9,6	29,9	10,2	27,9	10,9
	6*	36,0	9,1	34,0	9,8	32,6	10,3	31,0	10,8	29,0	11,5
	7	36,5	9,6	34,6	10,4	33,4	10,8	31,7	11,4	29,5	12,1
	8	37,2	10,1	35,2	10,9	34,0	11,4	32,2	11,9	30,0	12,6
	9	38,0	10,9	36,0	11,8	34,8	12,2	33,0	12,7	31,0	13,4
	10	39,0	11,8	37,1	12,7	36,0	13,5	34,0	13,6	32,0	14,3
M4AC150C	5*	41,7	9,5	39,4	10,4	37,8	10,9	35,8	11,5	33,4	12,3
	6*	43,2	10,3	40,8	11,1	39,2	11,6	37,2	12,2	34,8	13,0
	7	43,8	10,8	41,6	11,7	40,0	12,2	38,0	12,8	35,4	13,7
	8	44,6	11,4	42,2	12,3	40,8	12,8	38,6	13,5	36,0	14,2
	9	45,6	12,3	43,2	13,3	41,7	13,8	39,6	14,4	37,2	15,2
	10	46,8	13,3	44,5	14,3	43,2	15,3	40,8	15,3	38,4	16,5

**Notes:** The power input is for compressors only.

## Heat Pump

### Cooling Mode

Unit Size	Leaving water temperature °C	Ambient Temperature °C									
		28		32		35		40		42	
		Cooling Cap.ty kW	Power input kW	Cooling Cap.ty kW	Power input kW	Cooling Cap.ty kW	Power input kW	Cooling Cap.ty kW	Power input kW	Cooling Cap.ty kW	Power input kW
M4AC080CR	5*	22,6	6,8	21,4	7,5	20,5	7,8	19,4	8,3	18,1	8,8
	6*	23,4	7,3	22,1	8,0	21,2	8,4	20,1	8,8	18,9	9,4
	7	23,8	7,7	22,5	8,5	21,7	8,8	20,6	9,2	19,2	9,9
	8	24,2	8,1	22,9	8,9	22,1	9,2	20,9	9,7	19,5	10,3
	9	24,7	8,8	23,4	9,6	22,6	9,9	21,5	10,3	20,1	10,9
	10	25,4	9,5	24,1	10,3	23,4	11,0	22,1	11,0	20,8	11,6
M4AC100CR	5*	26,9	7,7	25,4	8,4	24,4	8,8	23,1	9,3	21,5	9,9
	6*	27,8	8,3	26,3	9,0	25,2	9,4	23,9	9,8	22,4	10,5
	7	28,2	8,7	26,8	9,5	25,8	9,8	24,5	10,3	22,8	11,0
	8	28,8	9,2	27,2	9,9	26,3	10,3	24,9	10,8	23,2	11,5
	9	29,4	9,9	27,9	10,7	26,9	11,1	25,5	11,6	23,9	12,2
	10	30,2	10,7	28,7	11,5	27,8	12,3	26,3	12,4	24,8	13,0
M4AC120CR	5*	33,6	8,6	31,8	9,4	30,5	9,8	28,9	10,4	26,9	11,1
	6*	34,8	9,3	32,8	10,1	31,5	10,5	29,9	11,0	28,1	11,8
	7	35,3	9,8	33,5	10,6	32,2	11,0	30,6	11,6	28,5	12,4
	8	36,0	10,3	34,0	11,2	32,9	11,6	31,1	12,1	29,0	12,9
	9	36,8	11,2	34,8	12,0	33,6	12,4	31,9	13,0	29,9	13,7
	10	37,7	12,0	35,9	12,9	34,8	13,8	32,9	13,9	31,0	14,6
M4AC150CR	5*	40,3	9,7	38,1	10,6	36,6	11,1	34,6	11,7	32,3	12,5
	6*	41,7	10,5	39,4	11,4	37,8	11,9	35,9	12,5	33,7	13,3
	7	42,4	11,0	40,2	12,0	38,7	12,5	36,7	13,1	34,2	14,0
	8	43,1	11,7	40,8	12,6	39,4	13,1	37,3	13,7	34,8	14,5
	9	44,1	12,6	41,8	13,6	40,3	14,0	38,3	14,7	35,9	15,5
	10	45,3	13,6	43,0	14,6	41,7	15,6	39,5	15,7	37,1	16,5

**Notes:** The power input is for compressors only.

# Heat Pump

## Heating Mode

Unit Size	Leaving water temperature °C	Ambient Temperature °C									
		-5		0		4		7		10	
		Heating Cap.ty kW	Power input kW	Heating Cap.ty kW	Power input kW	Heating Cap.ty kW	Power input kW	Heating Cap.ty kW	Power input kW	Heating Cap.ty kW	Power input kW
M4AC080CR	35	23,0	6,1	24,4	6,7	26,1	7,3	26,9	7,6	27,4	8,1
	40	22,5	6,7	23,8	7,4	25,3	7,8	26,1	8,3	27,1	8,6
	45	22,0	6,8	23,3	7,5	24,8	8,3	25,6	8,8	26,6	9,2
	50	21,5	7,5	22,8	8,1	24,3	8,7	25,1	9,1	26,0	9,5
	55	20,5	7,9	21,7	8,6	23,7	9,1	24,2	9,6	25,3	9,7
M4AC100CR	35	27,1	7,0	28,7	7,8	30,8	8,4	31,7	8,7	32,3	9,3
	40	26,5	7,7	28,0	8,5	29,9	9,0	30,8	9,6	31,9	9,9
	45	25,9	7,8	27,4	8,7	29,2	9,6	30,2	10,1	31,3	10,6
	50	25,3	8,6	26,8	9,4	28,7	10,0	29,6	10,5	30,7	11,0
	55	24,1	9,1	25,6	9,9	27,9	10,5	28,5	11,0	29,9	11,2
M4AC120CR	35	32,7	7,9	34,6	8,8	37,0	9,5	38,1	9,8	38,9	10,5
	40	32,0	8,7	33,8	9,6	36,0	10,2	37,0	10,8	38,5	11,1
	45	31,2	8,8	33,0	9,8	35,2	10,8	36,3	11,4	37,7	11,9
	50	30,5	9,7	32,3	10,6	34,5	11,3	35,6	11,9	37,0	12,4
	55	29,1	10,3	30,9	11,2	33,6	11,9	34,3	12,4	36,0	12,6
M4AC150CR	35	37,3	9,3	39,5	10,3	42,3	11,2	43,5	11,6	44,4	12,4
	40	36,5	10,3	38,6	11,3	41,0	12,0	42,3	12,7	43,9	13,1
	45	35,6	10,4	37,7	11,5	40,2	12,8	41,5	13,5	43,0	14,0
	50	34,8	11,5	36,9	12,5	39,4	13,3	40,6	14,0	42,2	14,6
	55	33,2	12,2	35,2	13,2	38,4	14,0	39,1	14,7	41,0	14,9

**Notes:** The power input is for compressors only.

## Technical Data

### Correction Factors With Glycol Use

Glycol %	Cooling Capacity	Water Flow	Pressure Drop
10	0.990	1.015	1.06
20	0.980	1.040	1.12
30	0.970	1.080	1.18
40	0.965	1.135	1.24

### Water Pressure Drop And Flow Rate

MODEL		Water Flow Rate		Water Pressure Drop	
		L/s	m <sup>3</sup> /h	kPa	Bar
M4AC080C		1.08	3.9	74	0.74
M4AC100C		1.31	4.7	82	0.82
M4AC120C		1.67	6.0	76	0.76
M4AC150C		2.0	7.2	74	0.74
M4AC080CR	Cooling	1.08	3.9	74	0.74
	Heating	1.14	4.1	72	0.72
M4AC100CR	Cooling	1.31	4.7	82	0.82
	Heating	1.39	5.0	80	0.80
M4AC120CR	Cooling	1.67	6.0	76	0.76
	Heating	1.78	6.4	74	0.74
M4AC150CR	Cooling	2.0	7.2	75	0.45
	Heating	2.11	7.6	73	0.73

**Model: M4AC 080C(R)/100C(R)/120C(R)/150C(R)**

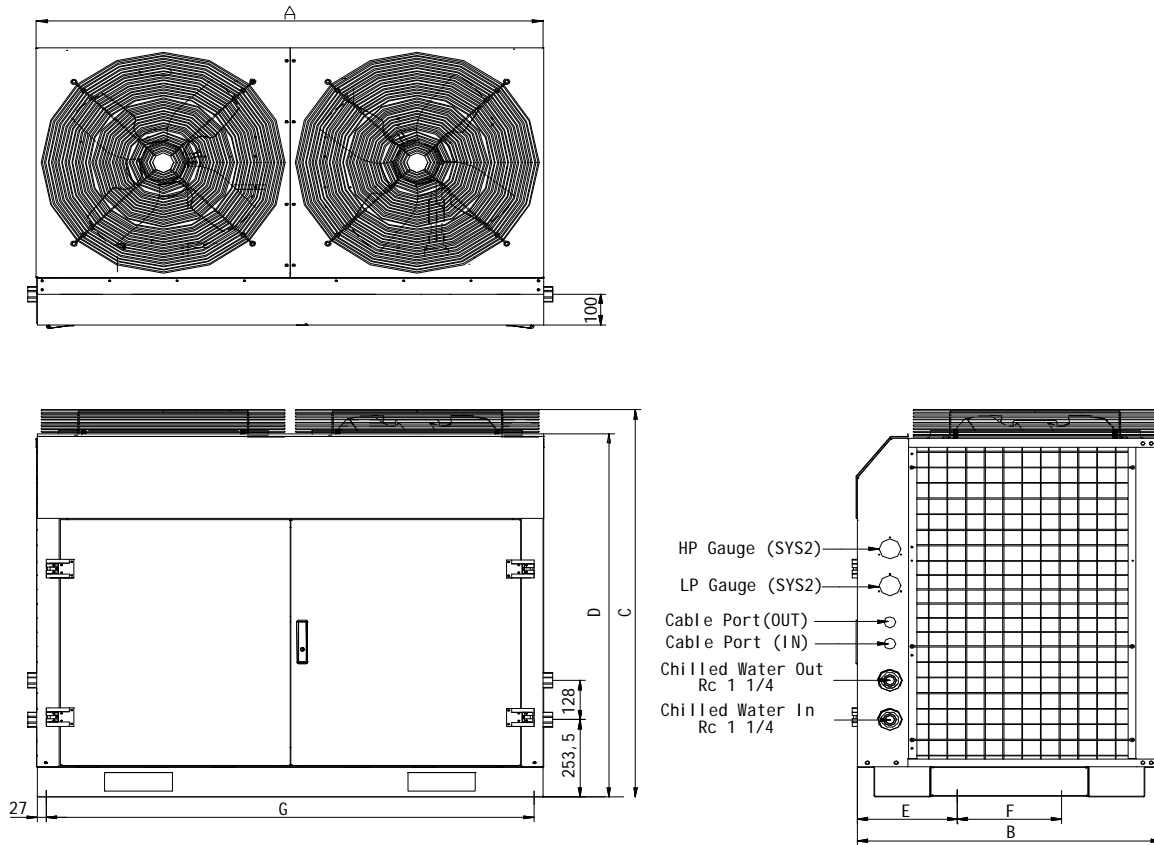

UNIT: mm

Model Dimension	M4AC080C(R)	M4AC100C(R)	M4AC120C(R)	M4AC150C(R)
A	1500	1500	1800	1800
B	900	900	1150	1150
C	1260	1260	1260	1260
D	1190	1190	1190	1190
E	297.5	297.5	347.5	347.5
F Mounting hole	307.5	307.5	307.5	307.5
G Mounting hole	1446	1446	1546	1546

# Model M4AC080C/100C Cooling only version

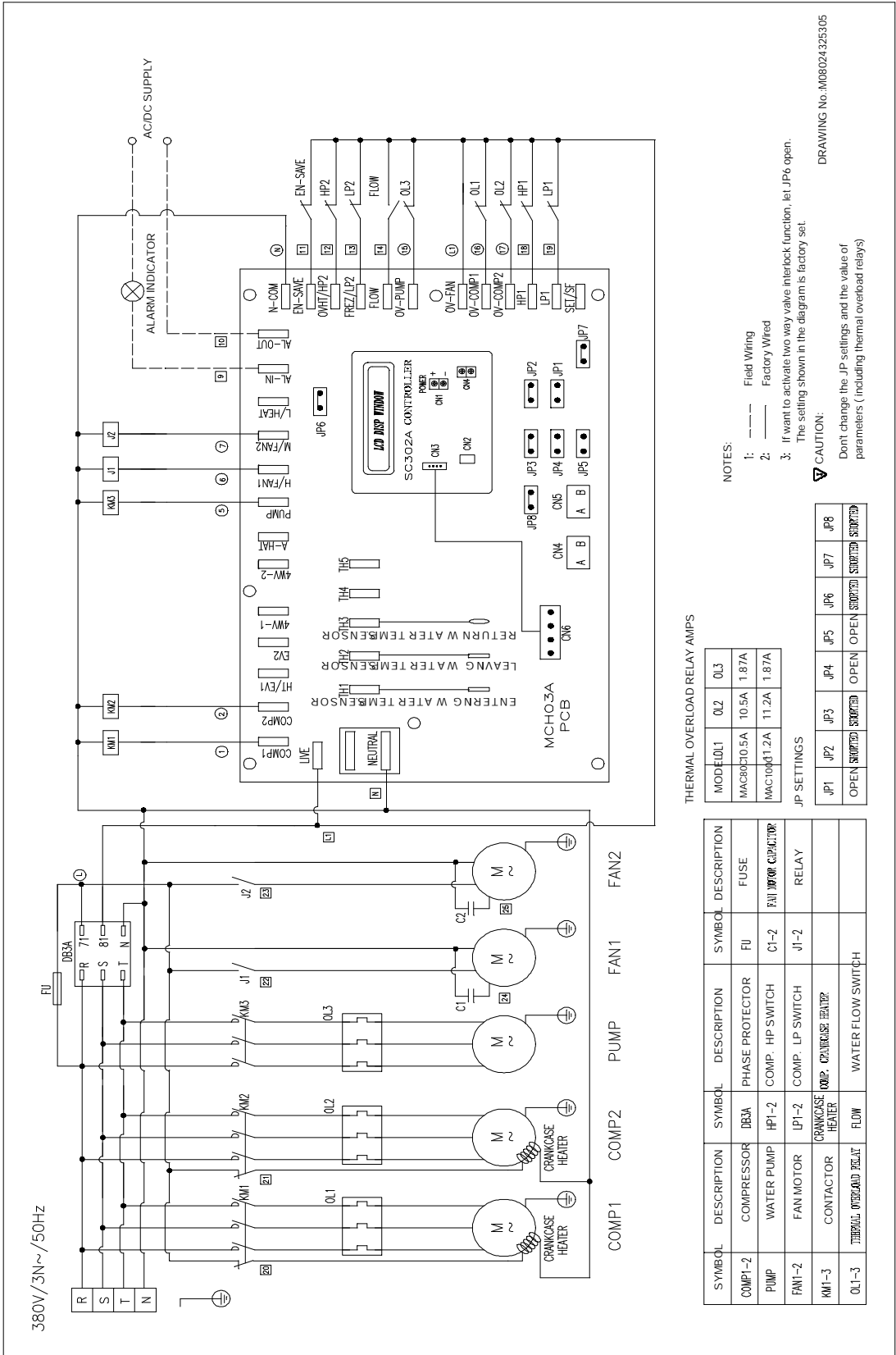



**Model M4AC080CR/100CR Heat Pump version**

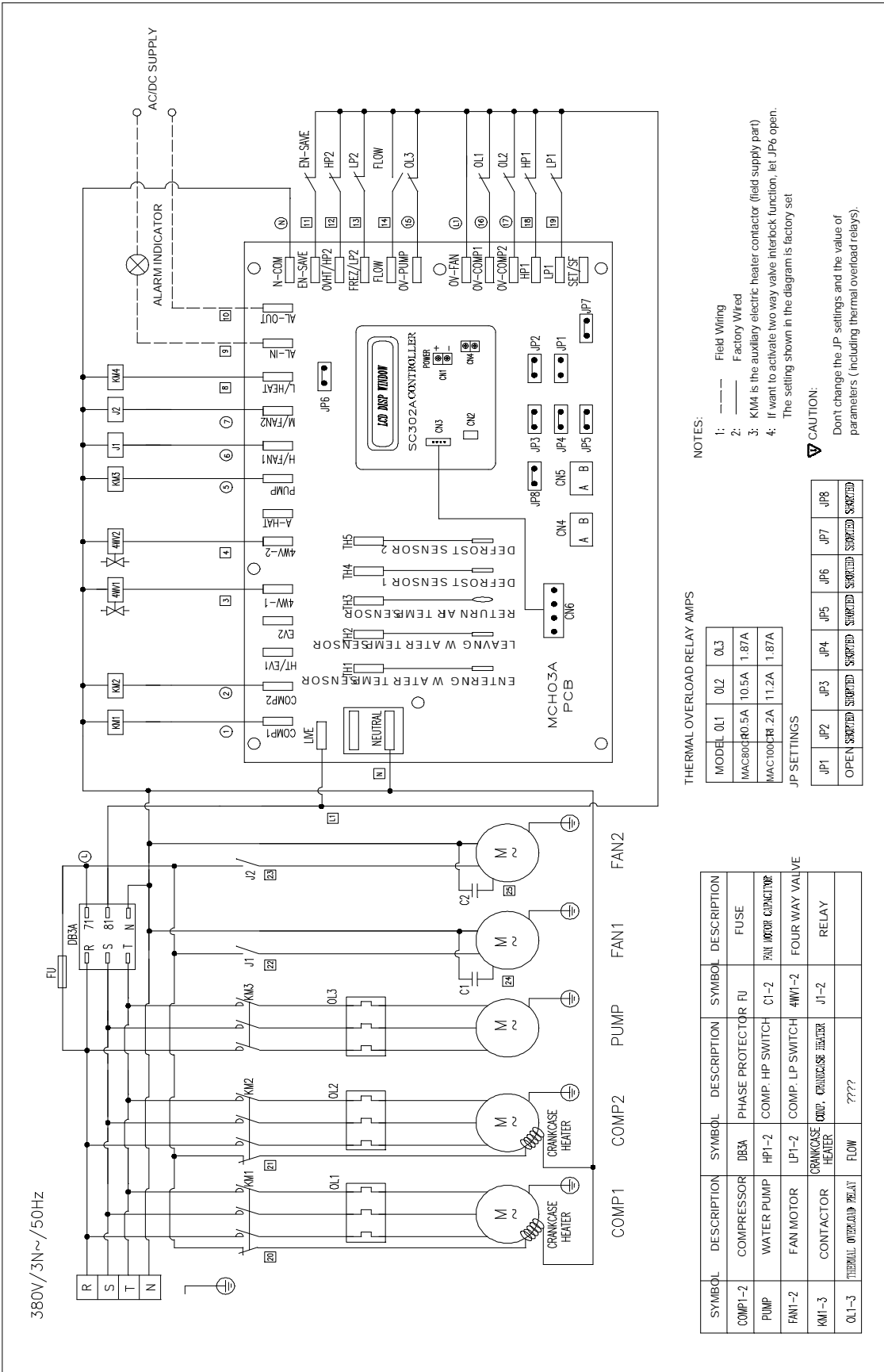

THERMAL OVERLOAD RELAY AMPS

MODEL	OL1	OL2	OL3
MAC80RO.5A	10.5A	1.87A	
MAC100CR.2A	11.2A	1.87A	

JP SETTINGS

JP1	JP2	JP3	JP4	JP5	JP6	JP7	JP8
OPEN	SHORTED	SHORTED	SHORTED	SHORTED	SHORTED	SHORTED	SHORTED

NOTES:

- 1: Field Wiring
- 2: Factory Wired
- 3: KM4 is the auxiliary electric heater contactor (field supply part) if want to activate two way valve interlock function, let JP6 open.
- 4: The setting shown in the diagram is factory set

**CAUTION:**

Don't change the JP settings and the value of parameters (including thermal overload relays).

SYMBOL	DESCRIPTION	SYMBOL	DESCRIPTION	SYMBOL	DESCRIPTION
COMP1-2	COMPRESSOR	DB3A	PHASE PROTECTOR	FU	FUSE
PUMP	WATER PUMP	HP1-2	COMP. HP SWITCH	C1-2	PAIR MOTOR CAPACITOR
FAN1-2	FAN MOTOR	LP1-2	COMP. LP SWITCH	4W1-2	FOUR WAY VALVE
KM1-3	CONTACTOR	CRANKCASE HEATER	CRANKCASE HEATER	J1-2	RELAY
OL1-3	THERMAL OVERLOAD RELAY	FLOW	????		

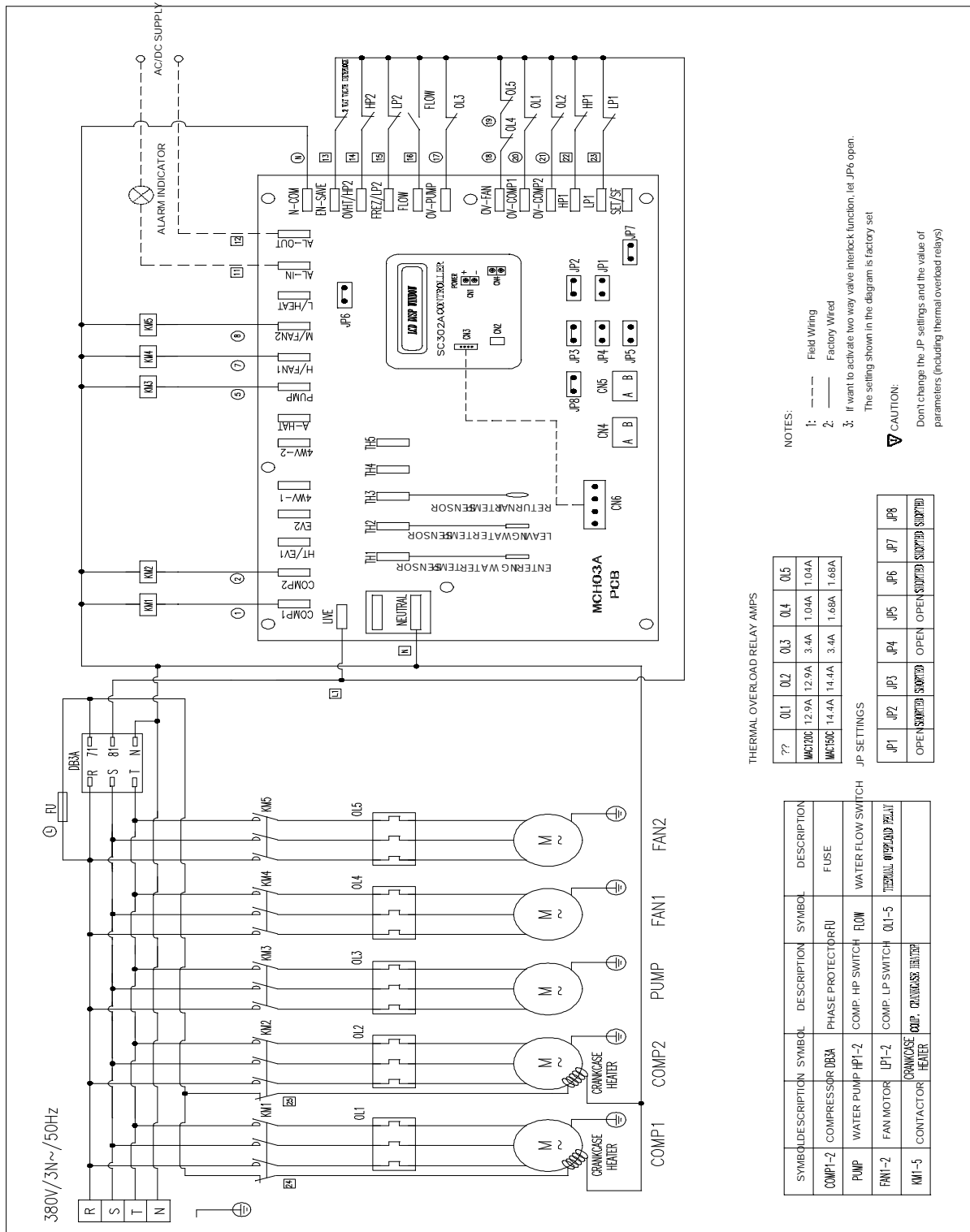

NOTES:

- Field Wiring
- Factory Wired
- If want to activate two way valve interlock function, let JP6 open.

The setting shown in the diagram is factory set

**CAUTION:**  
Don't change the JP settings and the value of parameters (including thermal overload relays)

THERMAL OVERLOAD RELAY AMPS

??	0.1	0.2	0.3	0.4	0.5
M4C120C	12.9A	12.9A	3.4A	1.04A	1.04A
M4C150C	14.4A	14.4A	3.4A	1.68A	1.68A

JP SETTINGS

JP1	JP2	JP3	JP4	JP5	JP6	JP7	JP8
OPEN	OPEN	OPEN	OPEN	OPEN	OPEN	OPEN	OPEN

SYMBOL/DESCRIPTION	SYMBOL	DESCRIPTION	SYMBOL	DESCRIPTION
COMP1-2 COMPRESSOR DB3A	PHASE PROTECTOR RU			FUSE
PUMP WATER PUMP HP1-2	COMP. HP SWITCH	FLOW		WATER FLOW SWITCH
FAN1-2 FAN MOTOR	COMP. LP SWITCH	OL1-5		TERMINAL OVERLOAD RELAY
KM1-5 CONTACTOR	COMP. CRANKCASE HEATER			

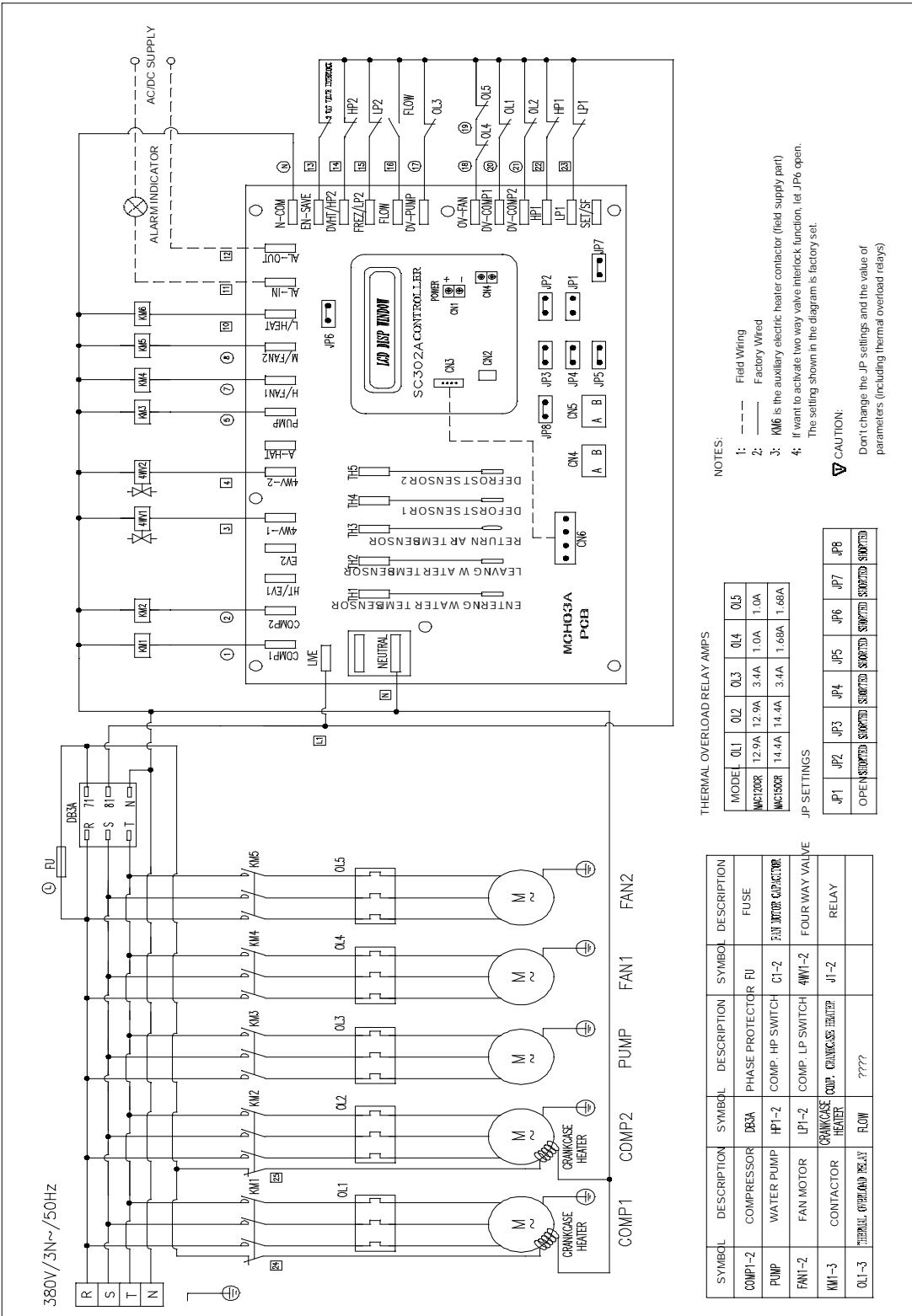

THERMAL OVERLOAD RELAY AMPS

MODEL	OL1	OL2	OL3	OL4	OL5
M4C120CR	12.9A	12.9A	3.4A	1.0A	1.0A
M4C150CR	14.4A	14.4A	3.4A	1.68A	1.68A

JP SETTINGS

JP1	JP2	JP3	JP4	JP5	JP6	JP7	JP8
OPEN	STARTED	STARTED	STARTED	STARTED	STARTED	STARTED	STARTED

SYMBOL	DESCRIPTION	SYMBOL	DESCRIPTION	SYMBOL	DESCRIPTION
COMP1-2	COMPRESSOR	DB3A	PHASE PROTECTOR	FU	FUSE
PUMP	WATER PUMP	HP1-2	COMP. HP SWITCH	CT-2	FAN MOTOR CONTACTOR
FAN1-2	FAN MOTOR	LP1-2	COMP. LP SWITCH	4W1-2	FOUR WAY VALVE
KM1-3	CONTACTOR	CRANKCASE HEATER	CRANKCASE HEATER	J1-2	RELAY
OL1-3	THERMAL OVERLOAD RELAY	FLOW	????		

NOTES:

- 1: --- Field Wiring
- 2: - - - Factory Wired
- 3: KM6 is the auxiliary electric heater contactor (field supply part)
- 4: If want to activate two way valve interlock function, let JP6 open. The setting shown in the diagram is factory set.

CAUTION:

Don't change the JP settings and the value of parameters (including thermal overload relays)

## Installation

### Installation Notice

This equipment must be installed by your dealer or authorized McQuay qualified personnel, and the installation must satisfy all the following requirements.

### Location

In order to achieve unit maximum capacity and long lifeoperation, the location selection should fulfill the following requirements:

- a) The location must be well ventilated, so that air can be drawn in and discharge out efficiently.

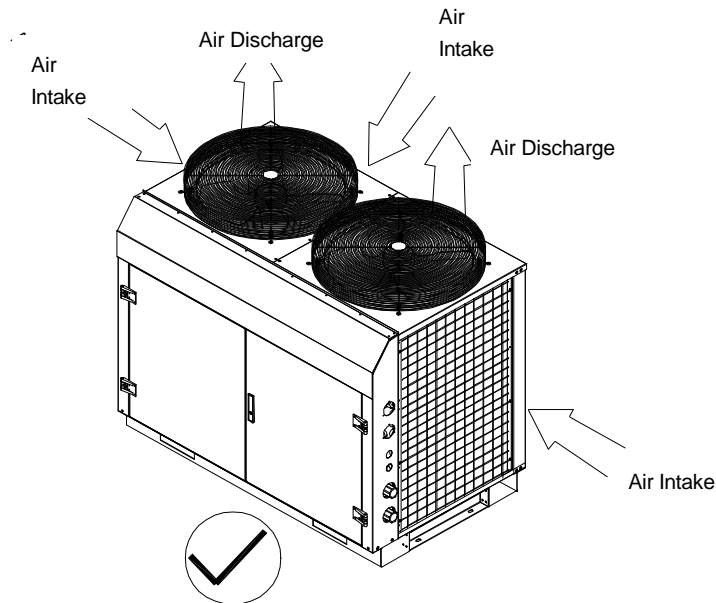

- b) Install the unit in such a way that the hot air discharge cannot be drawn in again by itself or other units.
- c) Ensure that there is no obstruction to air flow into or out of the unit. Remove obstacles which blocking intake or discharge air if exist.

Obstacles blocking air intake

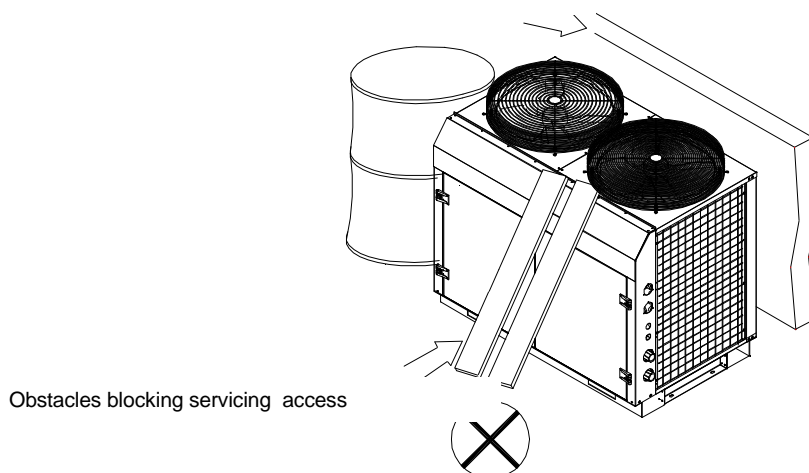

Obstacles blocking servicing access

d) For M4AC080C(R) to M4AC150C(R), if good ventilation cannot be guaranteed when unit being installed indoors, it is advisable to induce discharge air from air outlet to outdoors by installing duct which is as short as possible.

e) Support unit base up to create a space above foundation for ensuring free water drainage, and the stable foundation with level surface must be sufficiently durable against the unit weight.

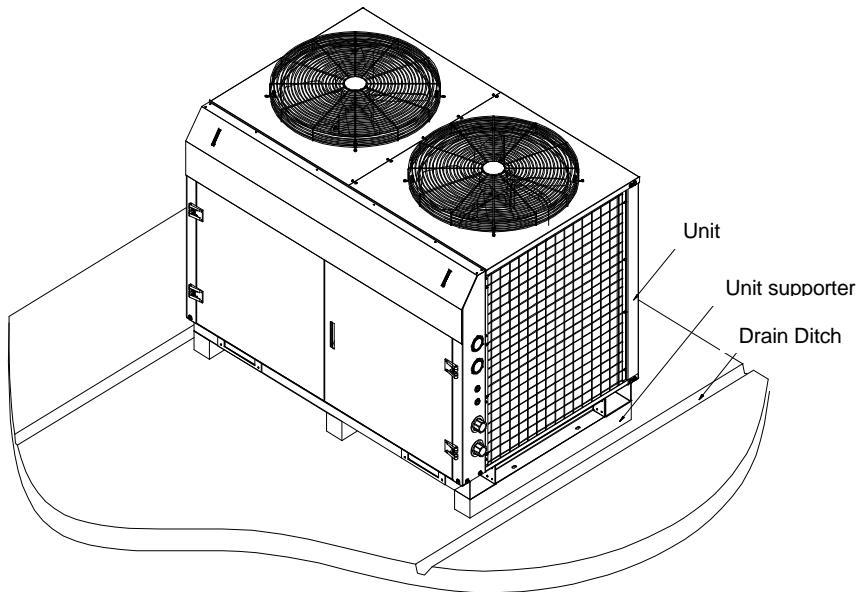

f) The location must not be susceptible to dust or oil to avoid condenser coil being choked by the contaminant. As the general safety precaution, it is advised that no flammable danger gas should be located near to the unit.

g) It is advised to have sufficient clearance around the unit for proper condenser air flow and to facilitate access for maintenance.( see clearance shown in figure below)

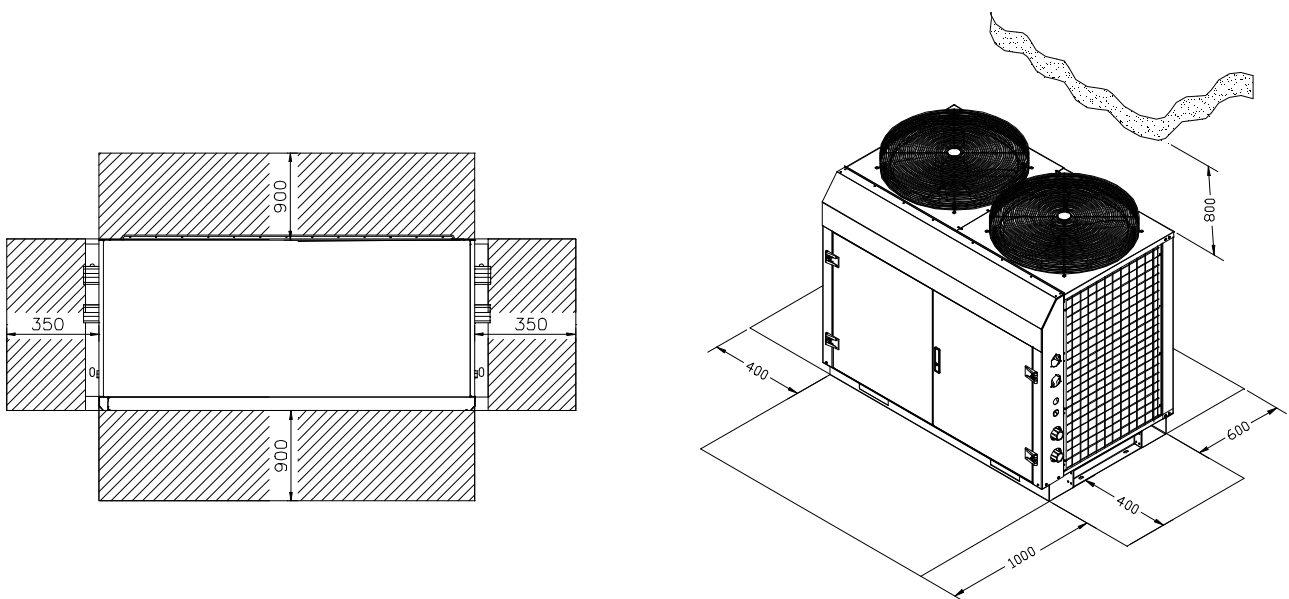

## Delivery and Lifting

When transporting the unit, it is advisable to use forklift or crane to do this work. Only the wooden skid base is allowed to be served as the weight-supporter.

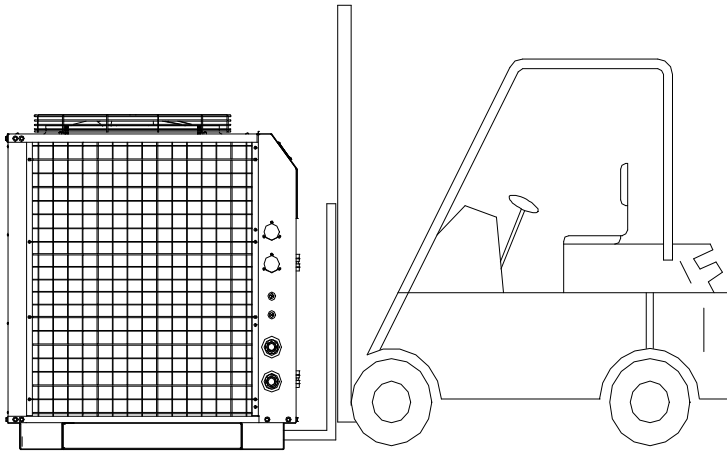

When hoisting, please keep the unit stable and without slope, meanwhile, be sure to avoid lifting cable contact with side heat exchanger, panel and unit's top part.

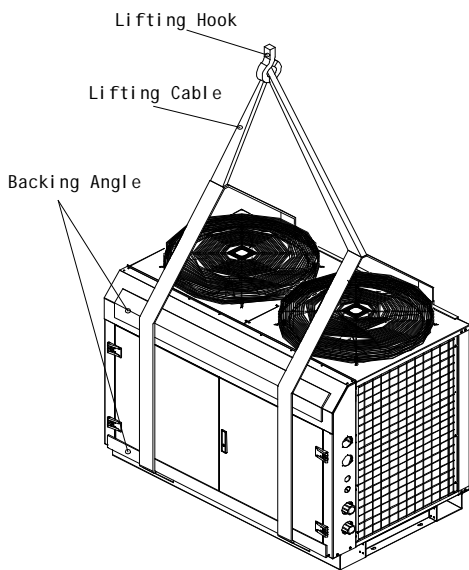

After deciding the mounting location, remove the skid base by unfastening the bolts.

## Mounting

When mounting, please use foundation bolts or expansion bolts to fasten the unit with foundation supporter.

It is advisable to pad the unit bottom against foundation by using vibration absorption rubber to prevent noise and vibration.

## Chilled Water Piping

Chilled water piping must be insulated and waterproof to avoid performance loss and moisture condensing on it.

To guarantee the chilled water quality, the water strainer shipped with unit must be installed on the chilled water in pipe.

Both chilled water inlet and outlet port are external taper thread connections.

When performing water pipe connection, use gripping pliers to fix the unit connections to avoid the reserved connections on unit being directly suffered from revolving torque when fastening.

Slide panel

Chilled water in out pipe

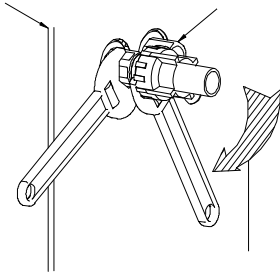

Air vent valve should be installed at highest points on chilled water piping system, see detailed information in “chilled water system installation schematic diagram”. After completing chilled water piping, carry out leak detection and 0.4MPa pressure test to ensure having no fault, then fully fill water in system, open air vent valve, purge all the air trapped in the piping system, after that shut off the air vent valve. Water drainage valve should be installed at lowest points on chilled water piping system.

In order to achieve the unit long-life operation, it is recommended to give first priority to new type plastic water pipe such as PP-R, PVC, never use galvanized steel pipe when choosing the material of water pipe.

#### **Caution:**

The accessory strainer shipped with unit must be installed on water in pipe, otherwise failure of the unit may be caused.

Never put the chiller into the condition of being operated with very oily, salty or acidic water, because these substances may lead to capacity drop and unit damage. Be sure to use clean water when filling in the water circuit to avoid heavy corrosion and choking of the system.

Don't use the water pump equipped in unit to clean piping. If using the pump to clean is required, you can fill clean water in system at water in side, meanwhile make the pump running, please conduct 30-minute pump operation, then clean the strainer.

#### **Notes:**

The design, construction and acceptance check of the hydraulic system should respectively refer to and comply with the corresponding manual, code and standard.

### **Power Connection**

Laws and regulations concerning electrical wiring work vary by country. Therefore, work should basically be performed according to the regulations of each country.

Before power connection, make sure that your local power supply type accords with the unit nameplate.

Please use suitable size dedicated wire to power this unit. The connections must be made secured without tension the terminals.

All electric work must be performed by licensed technician according to local regulations and the instructions given in this catalogue.

The unit must be properly earth connected. Do not connect the earth wire to gas pipe, city water pipe or telephone wire, improper earth connection may cause electrical shock.

Please mount electric leak protection breaker to avoid electric shock.

For three phase unit, please ensure correct phase sequence, make L1, L2, L3 correspond with R, S, T on terminal block respectively, otherwise the system cannot be started and the controller has no display.

Every wire should be firmly connected without tension to the cables and terminals.

All cables should not contact with refrigerating piping and moveable components such as compressor and fan motor etc.

### Caution

At emergency (if you smell something burning), stop operation and turn the power source switch off, ask for your dealer's instruction. Continuing the operation without eliminating the emergency state may cause a machine trouble, fire, or electrical shock.

Don't extend your fingers or other foreign pieces such as stick into unit air outlet, otherwise the unit could be damaged or you could be injured.

### Electrical Data

Model	M4AC 080C(CR)	M4AC100C(CR)
Power Supply	380v/3n~/50hz	
Total Input( W)	8770	10570
Running Current( A)	17.5	20.1
Power Cable	Cross Section Area(Mm <sup>2</sup> )	6
	Q.ty	5

Model	M4AC 120C(CR)	M4AC150C(CR)
Power Supply	380V/3N~/50Hz	
Total Input( W)	12920	15500
Running Current( A)	24.8	28.5
Power Cable	Cross Section Area(Mm <sup>2</sup> )	6
	Q.ty	5

### Electrical Connection Of Auxiliary Electric Heater

If auxiliary electric heater or auxiliary gas heater installation is required, please do installation after thoroughly reading corresponding manual. Carry out the electrical connection according to the diagram below so that achieve their automatic on/off governed by the unit controller. In addition, contact with local McQuay service representative for performing trial startup.

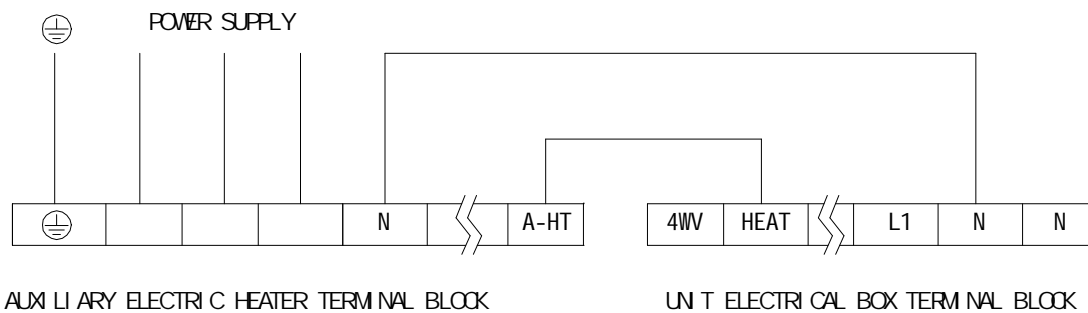

## Servicing and Maintenance

### Servicing

Service and maintenance are to be performed only by qualified personnel who are well trained with refrigeration engineering. Before restart the unit, do a thorough check and analysis of the unit safety control components.

The optimum design of the refrigerating system eliminates the possibility of problems being occurred during normal operation. There is no need to conduct any maintenance to refrigerant piping if the unit is under normal running.



McQuay designers have given full consideration to make servicing convenient during unit development. After opening service panel, both servicing and maintenance can be easily carried out.

Under normal environment, the only work needed is checking the return air way and cleaning the heat exchange surface regularly at month or season interval decided on operating condition.

If the surrounding is very dirty or oily, for maintaining superior performance and sufficient capacity, please ask specialized personnel to do regular cleaning of heat exchanger.

## Maintenance

For keeping consistent performance and durability with safe, effective and long-life operation, always conduct proper and regular maintenance to the unit.

For long period of operation time, the heat exchanger will become dirty impairing its effectiveness and reducing the performance of the air conditioner. Consult your local dealer on the cleaning of the heat exchanger.

No main maintenance or servicing needed for the internal water circuit except the water pump failure. It is advised that regular check on the strainer should be conducted and replace the water strainer if the strainer is dirty or clogged.

Always check the water level in the system, for the target of protecting the moving components in the hydraulic kit from overheating, excessive wearing and water freeze.

All the chilled water in the hydraulic system must be drained out completely during unit shutdown in winter, to avoid water piping damage due to freeze.

## Troubleshooting

Symptoms	Possible Causes	Remedial Action
1. Compressor does not start	No power supply. Fuses blown or automatic circuit breakdown open.  Unit is stopped because a safety has tripped.  Loose wires.  · Compressor faulty.	Check power supply. Look for short circuit or grounded wires in motor windings. Replace fuses and reset circuit breakers when the fault has been corrected. Check tightness and soundness of all electrical connections. Determine the type of safety shut down and correct the default before the unit is restarted. Check wire connections and tighten terminal screws. Contact local dealer.
2. Fan does not work	No power supply. Fan motor faulty.	Check power supply. Contact local dealer.
3. Air conditioner does work, but insufficient cooling.	Thermostat setting too high. Condenser coil dirty. Obstacle blocking air inlet or outlet of the unit. Insufficient refrigerant in the system. · improper water flow rate. Water in the system is contaminated.	Reset thermostat Contact local dealer. Remove the obstacle.  Contact local dealer.  Contact local dealer. Contact local dealer.

## Troubleshooting With Microprocessor

Error Code	Possible Causes	Solutions
E1	Return water sensor contact loose/short	Contact with the dealer, check and rewire it
E2	Supply water sensor contact loose/short	Contact with the dealer, check and rewire it
E3	Return air sensor contact loose/short	Contact with the dealer, check and rewire it
E4	System 1 defrosting sensor contact loose/short	Contact with the dealer, check and rewire it
E7	Insufficient water flow	Adjust water flow rate, check and clean strainer
E8	Water pump overload	Contact with the dealer
EA	Compressor 1 overload	Contact with the dealer
EC	Compressor 1 high pressure cutout	Contact with the dealer
ED	Compressor 1 low pressure cutout	Contact with the dealer
EE	RAM access failure	Contact with the dealer
EF	Too low supply water temperature when cooling	Contact with the dealer

When other code is displayed, please consult specialized personnel.  
See detailed indoor controller operation in corresponding instruction manual.

## Schematic Diagrams

### Cooling Only Version (M4AC080C/100C/120C/150C)

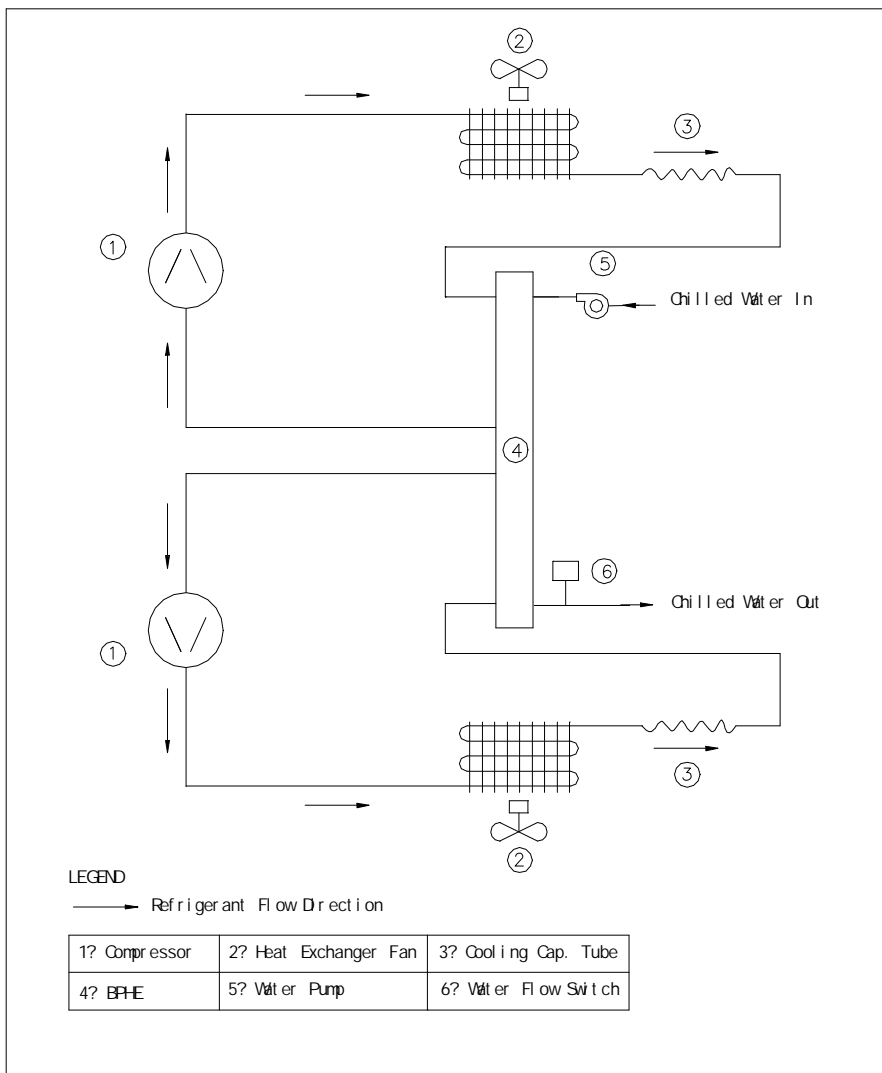

# Schematic Diagrams

## Heat Pump Version (M4AC080CR/100CR/120CR/150CR)

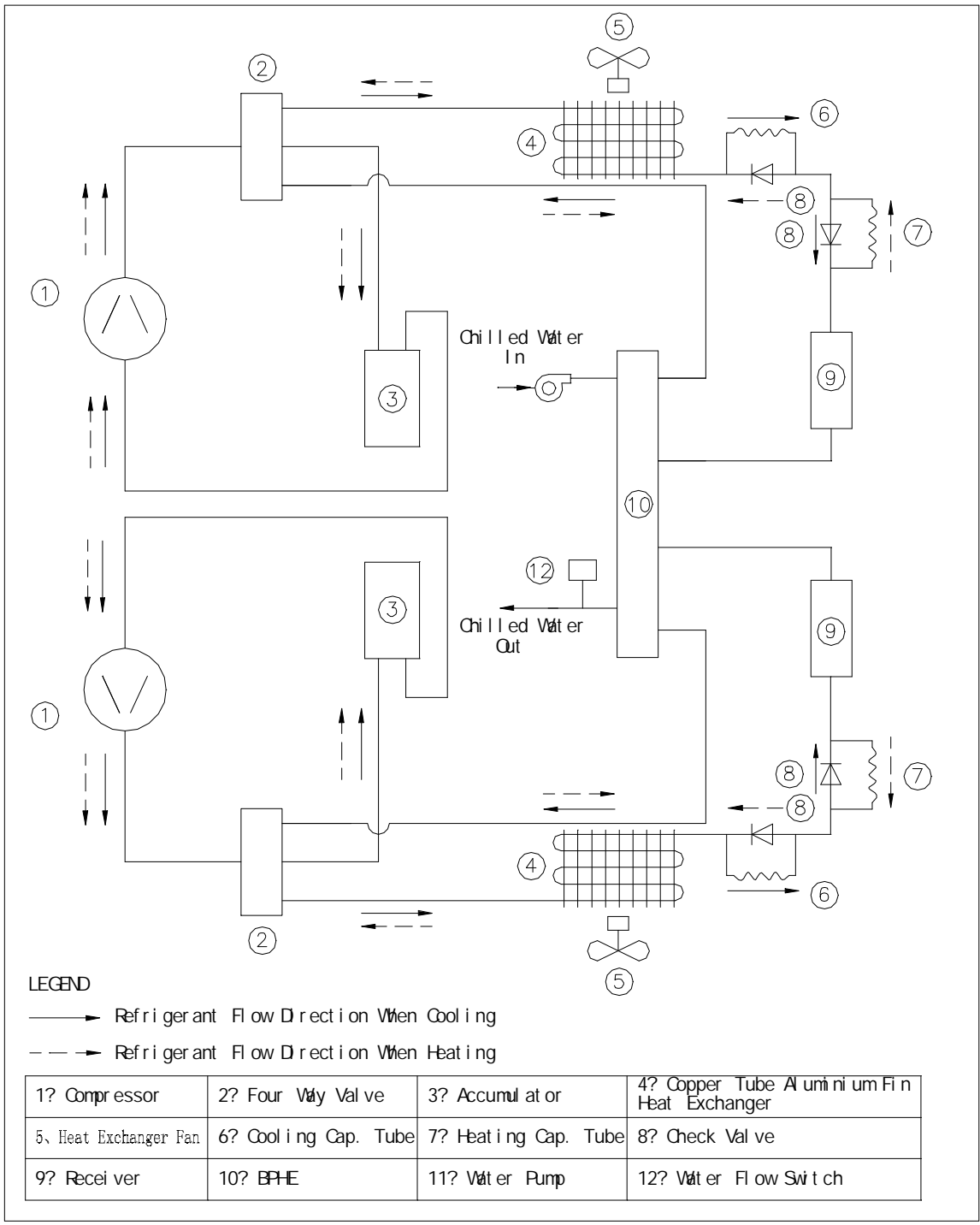

We reserve the right to make changes in design and construction at any time without notice, thus the cover and data are not binding

ITEM	NAME	Q.T.Y
1	FAN GUARD	2
2	TOP PANEL	2
3	FRONT PANEL SUPPORT	1
4	LEFT & RIGHT COIL GUARD	2
5	LEFT COIL ASSY.	1
6	SEPERATE PANEL ASSY.	1
7	LEFT & RIGHT SIDE PANEL ASSY.	2
8	FRONT PANEL ASSY.	1
9	ELECTRICAL BOX SUPPORT	2
10	ELECTRICAL BOX ASSY.	1
11	WATER-OUT PIPE ASSY.	1
12	WATER-IN PIPE ASSY.	1
13	LEFT SERVICE PANEL ASSY.	1
14	RIGHT SERVICE PANEL ASSY.	1
15	FAN	2
16	FAN MOTOR	2
17	FAN MOTOR SUPPORT	2
18	REAR COIL GUARD	2
19	LEFT & RIGHT VERTICAL SUPPORT	2
20	RIGHT COIL ASSY.	1
21	ACCUMULATOR	2
22	BPHE	1
23	COMPRESSOR	2
24	PUMP TO BPHE PIPE ASSY.	1
25	RECEIVER	2
26	WATER PUMP	1
27	BASE PAN ASSY.	1

